



AIM-50™

INSTALLATION MANUAL
SINGLE CEILING VERSION

PERFORMANCE RELIABILITY VALUE

The Right Light

EXAMINATION

Installation Manual

AIM-50™ Single Ceiling

The following models are covered in this manual:	
AIM-50™ Single Ceiling Version 120V	A50SC
AIM-50™ Single Ceiling Version 100V	A51SC
AIM-50™ Single Ceiling Version 240V	A52SC
AIM-50™ Single Ceiling Version 230V	A53SC

This product was designed and assembled in the U.S.A. by

BURTON MEDICAL PRODUCTS CORP.
21100 Lassen St.
Chatsworth, CA 91311
U.S.A.

**This manual to remain
with end user.**

Questions?
Tel. (800) 444-9909
(818) 701-8700
Fax (800) 765-1770
(818) 701-8725
www.burtonmedical.com

Table of Contents

Introduction	3
Symbols Used in This Manual.....	4
Transportation and Storage	4
Safety Precautions	5
Assembly Preparations	5
Support and Anchorage.....	5
Mounting Height.....	6
Range of Motion.....	7
Unpacking and Inspection	8
Single Ceiling Version installation	9
Ceiling Support Structure	9
Installing the Junction Box.....	9
Installing the Ceiling Casting.....	9
Installing the Down Tube	10
Connecting Power	12
Installing Wall Switch	13
Installing the Extender Arm with Spring Arm	14
Mounting the Light Head.....	15
Final Testing	17
Adjusting Arm Tension.....	17
Static Inspection	17
Declaration of Acceptance	17
Equipment Anchorage Diagrams	18
Cutting the Down Tube	20

This manual contains detailed information on the above, but the responsibility for effective and safe use of the product ultimately rests with the user. Products should at all times be handled by qualified staff; it is the responsibility of the user to ensure this is the case.

Introduction

Dear Installer,

Congratulations on your purchase of the AIM-50™ Examination Light!

The installation manual gives instructions on how to install the AIM-50™ Examination Light Single Ceiling Version. For instructions on operation, maintenance and further description of the product please refer to the Operation & Maintenance manual furnished with the product.

Please read these installation instructions very carefully and follow the safety instructions and requirements.



If there are any peculiar problems that have not been treated in sufficient detail in these installation instructions, please contact your supplier for your own safety.

This product was designed and manufactured in the U.S.A. by:
Burton Medical Products
21100 Lassen Street
Chatsworth, CA 91311
U.S.A.

Questions?
Tel: (800) 444-9909
(818) 701-8700
Fax: (800) 765-1770
(818) 701-8725
www.burtonmedical.com

Copyright © 2008 Burton Medical Products

Symbols Used in This Manual

 WARNING	Disregarding this instruction can present the risk of a serious or fatal injury.
 CAUTION	Disregarding this instruction can result in medium to light injury and damage to property.
 IMPORTANT	Provides usage tips and useful information.





Transportation and Storage

The following storage conditions apply:

- Temperature: 0°-70 °C (32-158°F)
- Relative humidity: 10 - 75 % (no condensation)
- Air pressure: 500 - 1060 hPa

Store only in closed or covered spaces; thereafter, the values of the operating conditions in the usage instructions apply.

Safety Precautions

	WARNING	Failure to properly follow installation and preventive maintenance instructions may result in mechanical failure.
	WARNING	Before undertaking any work, ensure that the branch circuit power is off and secured from accidentally being switched on again.
	NOTE	This light should only be installed by a qualified electrical contractor.
	NOTE	It is the responsibility of the customer to make sure the supporting wall / ceiling and the anchoring is safe, adequately strong and in compliance with all applicable building codes. (See: Static inspection on page 16 and the section Support and Anchorage below)

Assembly Preparations

Tools and Accessories Required:

- Drill
- Hacksaw
- Level
- 9/16" (14,3 mm) open-end wrench (or adjustable wrench)
- Wire cutter/stripper
- Allen key (3/32 in / 2,4 mm)
- Screwdriver, small flat-blade
- Wire nuts and wiring for supply connections

Support and Anchorage

To prevent sway and provide proper support of the light, the ceiling mount must be attached to a structurally-sound ceiling. Most ceilings will require adequate reinforcing to hold the light. The installing contractor is responsible for providing this reinforcement to suit the individual requirements of each installation. A typical reinforcement consists of a ¼" steel plate, the bottom surface of which is flush with the inside surface of the finished ceiling (e.g., acoustical tile) and connected firmly to the structural ceiling. Sway braces (e.g., made of angle iron) are recommended when there is more than 12" between the structural and finished ceilings. Make certain the installed plate is level or the arm(s) may "drift". Equipment anchorage diagrams are supplied with these instructions to help with the installation (see page 16). The diagrams were prepared by a California-licensed Structural Engineer. If the lights are installed accordingly, the systems will meet requirements of the State Seismic Codes.

Mounting Height

The proper height of the light should be set by the end user. This depends on the ceiling height, the height of the examination tables, types of procedures and the user's preferences. (See Figure 1 on page 7.) Due to the large vertical range of the light head (41 in / 1040 mm), the standard 20" down tube will fit most normal ceiling heights. The following table gives some recommendations and shows the range of the light with the different length down tubes.

Ceiling height	Down tube	Pivot point ¹	Lower limit Light head	Higher limit Light head
7.0 ft 2135 mm	Short 8" ²	66 in 1676 mm	42 in 1067 mm	83 in 2108 mm
7.5 ft 2285 mm	Standard 20"	60 in 1524 mm	36 in 914 mm	77 in 1956 mm
	Short 8" ³	72 in 1829 mm	48 in 1220 mm	89 in 2260 mm
8.0 ft 2440 mm	Standard 20"	66 in 1676 mm	42 in 1067 mm	83 in 2108 mm
9.0 ft 2745 mm	Standard 20"	78 in 1980 mm	54 in 1370 mm	95 in 2410 mm
10.0 ft 3050 mm	Standard 20"	90 in 2286 mm	66 in 1676 mm	107 in 2718 mm
	Long 42" ⁴	66 in 1676 mm	42 in 1067 mm	83 in 2108 mm
11.0 ft 3350 mm	Long 42"	78 in 1980 mm	54 in 1370 mm	95 in 2410 mm
12.0 ft 3660 mm	Long 42"	90 in 2286 mm	66 in 1676 mm	107 in 2718 mm

¹ Distance from the floor to the pivot point of the spring arm.

² Cut the standard down tube (from the top) and drill two new holes. See instructions on page 20.

³ Cut the standard down tube (from the top) and drill two new holes. See instructions on page 20.

⁴ Contact Burton to obtain a Long Down Tube.

Range of Motion

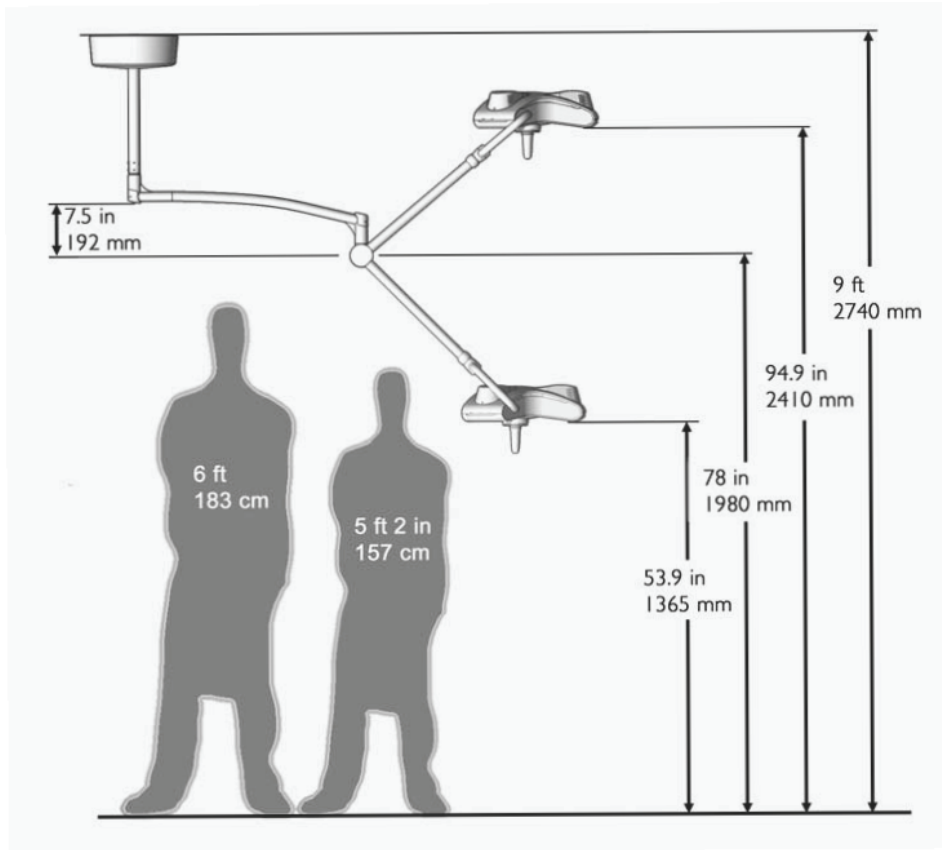

Figure 1: Vertical range of motion. Shown for 9 ft ceiling height.

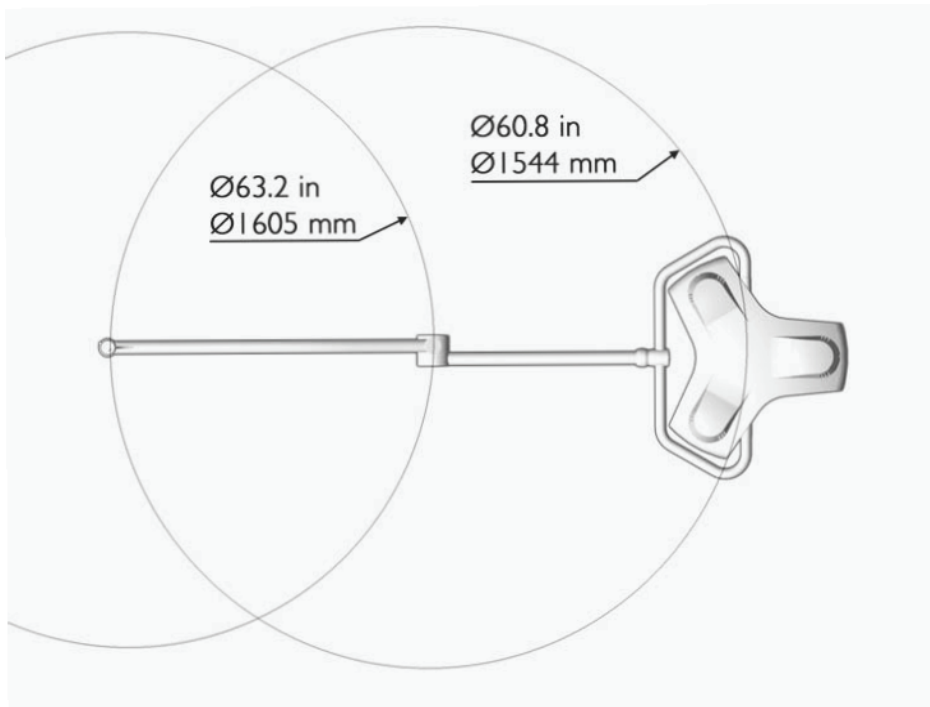

Figure 2: Horizontal range of motion

Unpacking and Inspection

Carefully unpack the cartons and match the parts received with the parts list enclosed.

Before Reporting Shortages:

1. Be sure you have received the correct number of boxes, cartons, etc., as shown on the bill of lading.
2. Check the entire shipment against the enclosed packing slip.
3. Items indicated in the column headed "Back Order" are not included in the shipment and will follow later.
4. Be sure that nothing has been removed from the cartons before they are checked by the individual in charge.
5. Empty all boxes completely, open all inside containers, and examine all packing material to ensure small articles are not overlooked.

If a Shortage or Damage Occurs:

1. You, the receiver, not Burton, are responsible for filing any claim(s) with the delivering carrier within five (5) days after receipt of the shipment.
2. If damage or shortage occurs in transit, the delivering carrier is required by law to make notation of a shortage or damage. This notation is to be made on the bill of lading.
3. If, in your opinion, there may be concealed damage, an agent from the delivering carrier is obligated to make an inspection after the goods are unpacked.
4. Do not destroy packing material until after the agent has made out his report.
5. All claims must be made to the carrier, not Burton.
6. Written authorization must be obtained from Burton before merchandise can be returned.

Single Ceiling Version Installation

Ceiling Support Structure

The engineer of record for the building shall provide a support structure designed to support weights and forces shown on the Equipment Anchorage Diagrams on page 17. When the support structure is in place the static inspection sheet on page 17 should be filled out.

Installing the Junction Box

The junction box should normally be placed on top of the support structure. Make sure the screw holes on the junction box plate correspond to the holes in the ceiling casting. When the ceiling plate is installed, the bolts will also hold the junction box.

If there isn't space for the junction box on top of the support structure, another suitable location in the ceiling can be used. It is also possible to use another junction box if that is more convenient.

Connecting wiring (contractor-supplied) must be minimum AWG 18 from the switch to the terminal block. Wiring and conduit must meet the NEC, local, and national fire protection codes.

Installing the Ceiling Casting

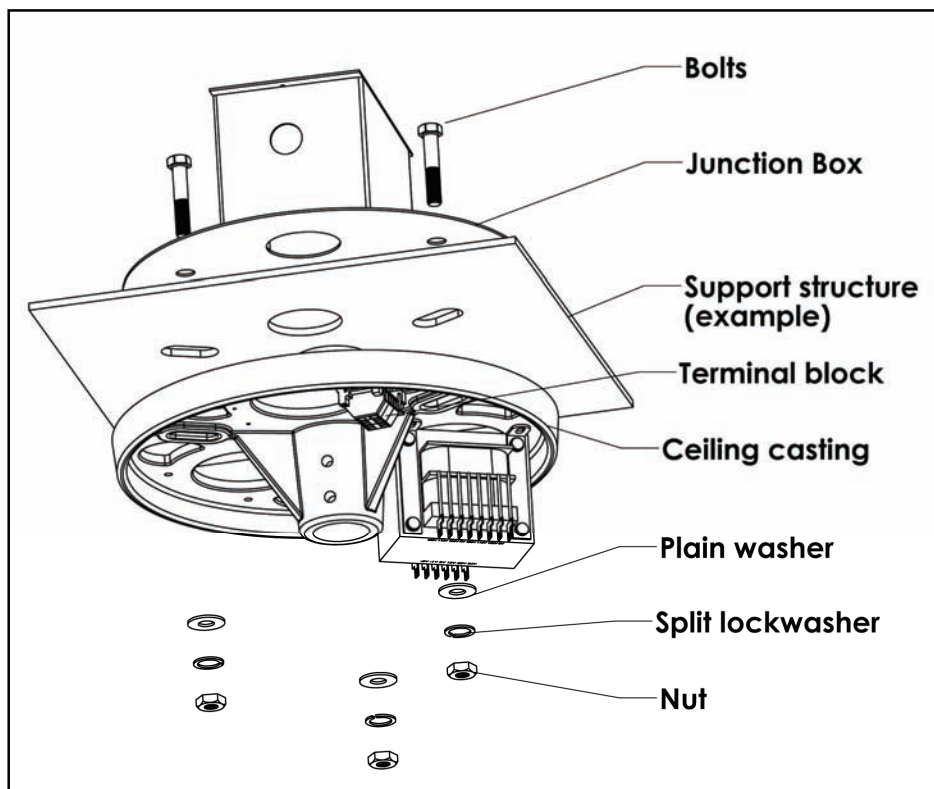

1. Mount the ceiling casting to the support structure. Make sure the hole in the ceiling casting below the terminal block aligns with the hole in the junction box. Use three (3) 3/8" bolts, plain washers, split lockwashers, and nuts in a triangular pattern. See Equipment Anchorage Diagrams on page 18 for details.

Installing the Down Tube

❗	NOTE	The down tube is pre-cut and pre-drilled at the factory and will suit most exam rooms with a ceiling height of 7.5-9 ft. See the section “Mounting height” on page 6 for further advice.
❗	NOTE	Be certain to assemble the bell housing to the down tube before attaching the down tube to the ceiling casting.

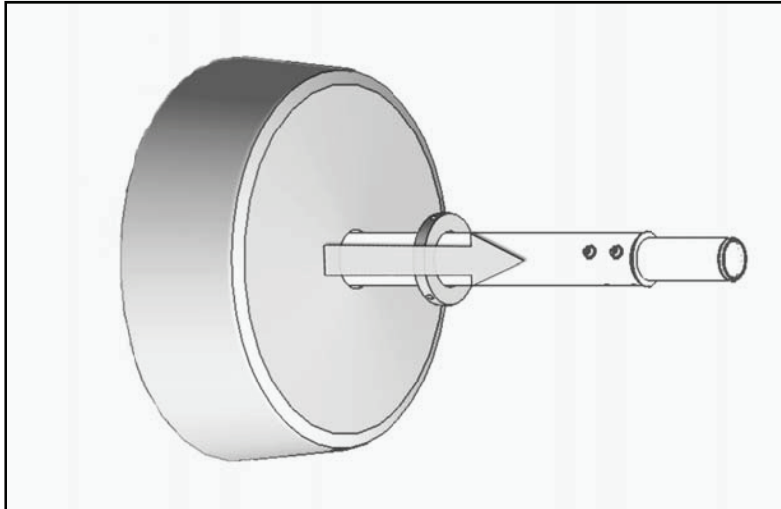

2. Slip the locking ring and the bell housing onto the down tube.

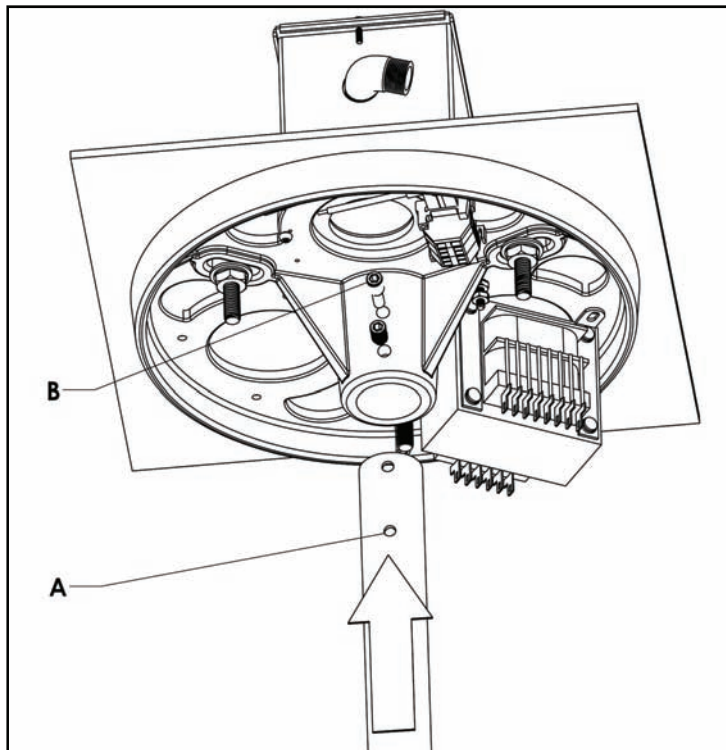

3. Assemble the down tube by sliding it up the center hole in the ceiling casting. Position the tube so that the lower hole (A) in the down tube is matching to the upper hole (B) in the ceiling casting. First fasten the upper set-screw, which is a dog-point screw. (Make sure it fully engages the matching hole in the down tube.) Then fasten the lower setscrew. Use Loctite® Threadlocker or similar on the screws to prevent them from becoming loose.

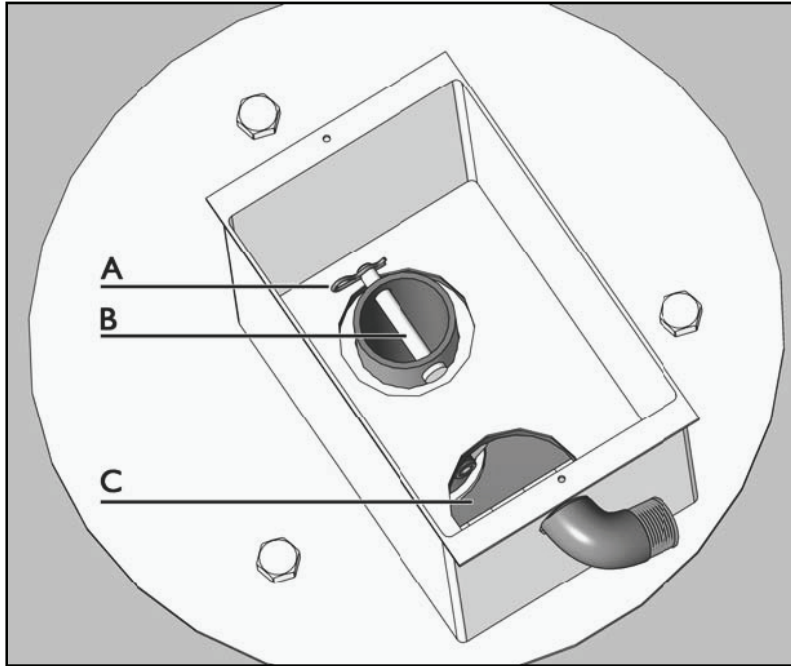

4. Approximately 1 inch of the down tube should be showing above the ceiling plate. A hole through the down tube will be accessible. Put the clevis pin (B) into the hole. Secure the clevis pin with the hairpin (A).
5. Feed the wires coming up out of the down tube down through the hole in the ceiling casting (C). The supply lines (from the wall switch) should also go through this hole.

Connecting Power

1. The branch power from the wall switch should now be connected to the terminal block, which is pre-mounted on the ceiling casting. To connect to the terminal block use the technique shown on the illustration to the right.

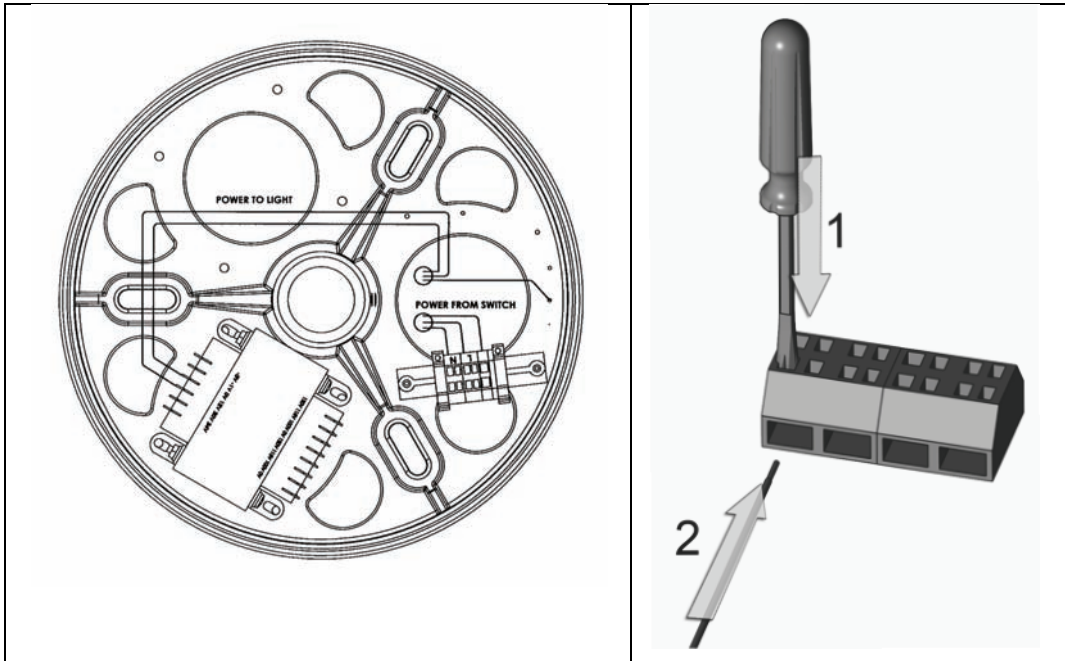

2. Connect the wires as shown on the illustration to the left. (Only the connections the installer needs to do are shown. For a complete wiring diagram, please refer to the Operation & Maintenance manual.)

The terminal block is marked with letters and numbers as follows:

- a) Lines up out of the down tube (to light fixture):
Connect the green ground wire to the ground point on the casting.
Connect the other two wires to terminals on the transformer
(Secondary terminals marked OV and 12V)
- b) Input Power (from wall switch):
Connect the green/yellow ground wire to the green terminal block.
Connect the neutral wire (normally white) to the terminal block marked "N"
Connect the live wire (normally black) to the terminal block marked "L"

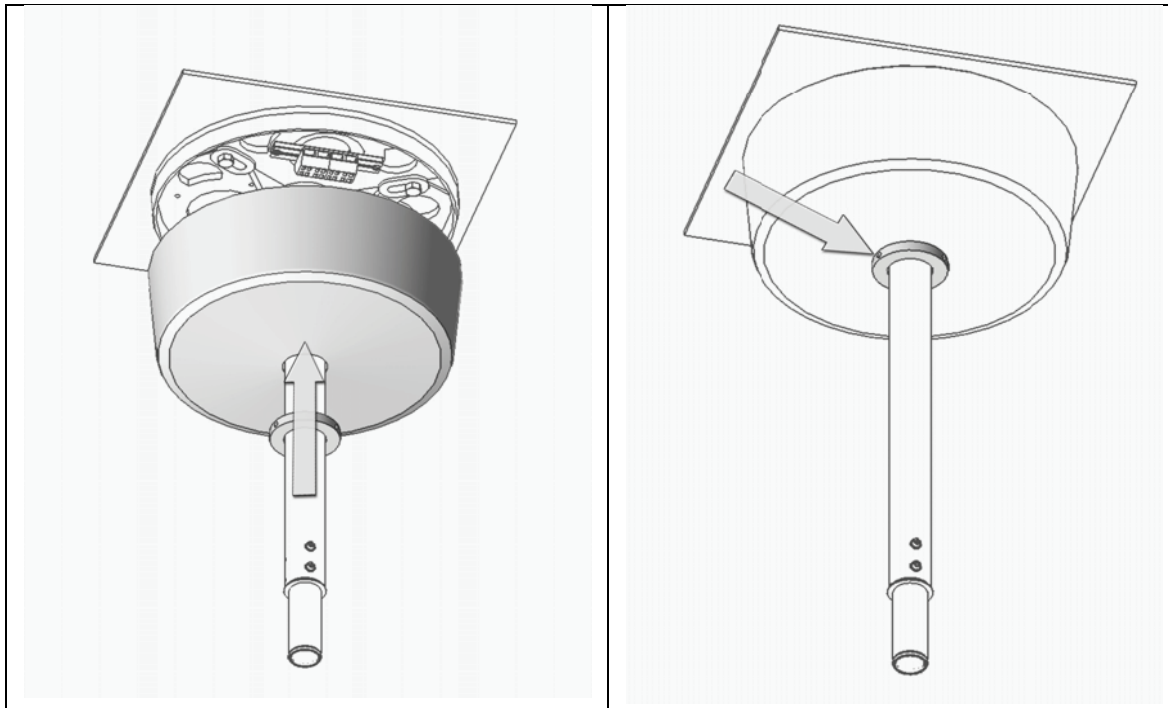

6. Push the bell housing and the lock ring up until it covers the ceiling plate. Tighten the two set-screws on the lock ring using an Allen key (3/32 in / 2,4 mm).

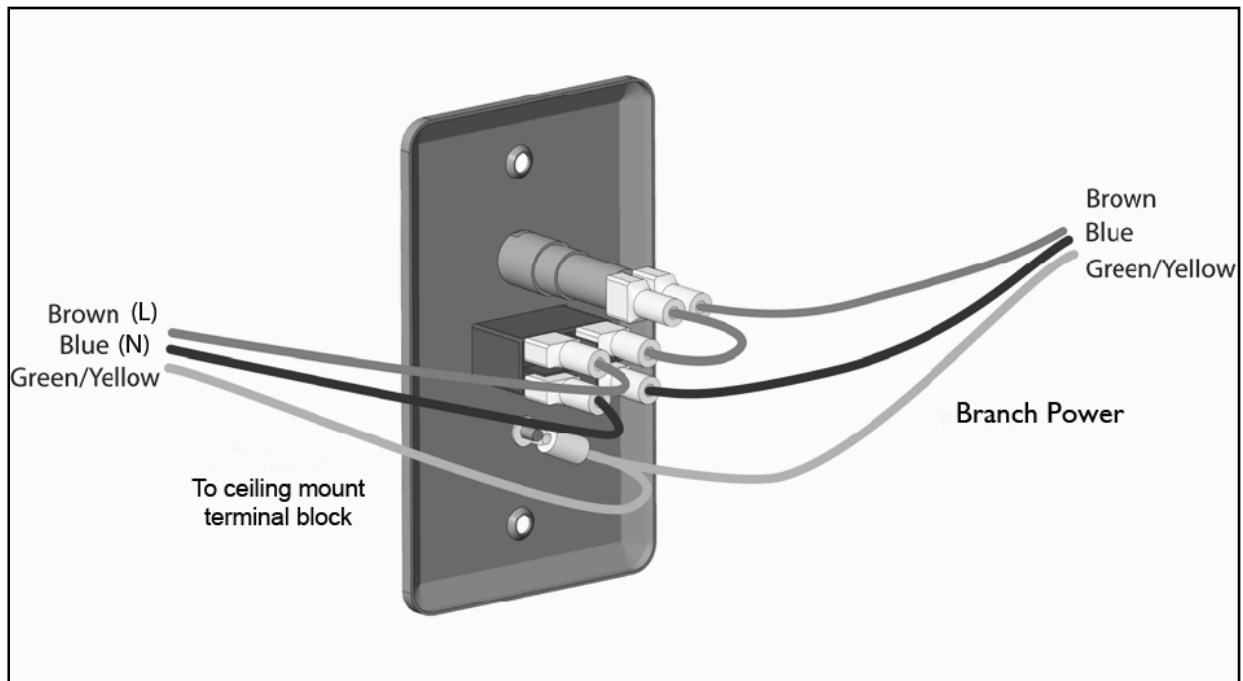

Installing Wall Switch



120 V version: Install wall switch furnished with the product to a standard junction box per local codes. The wires that go to the light fixture are labeled “to light fixture”.

100V / 230V, 240V versions: Install wall switch per local codes. Wall switch is not furnished with the product.

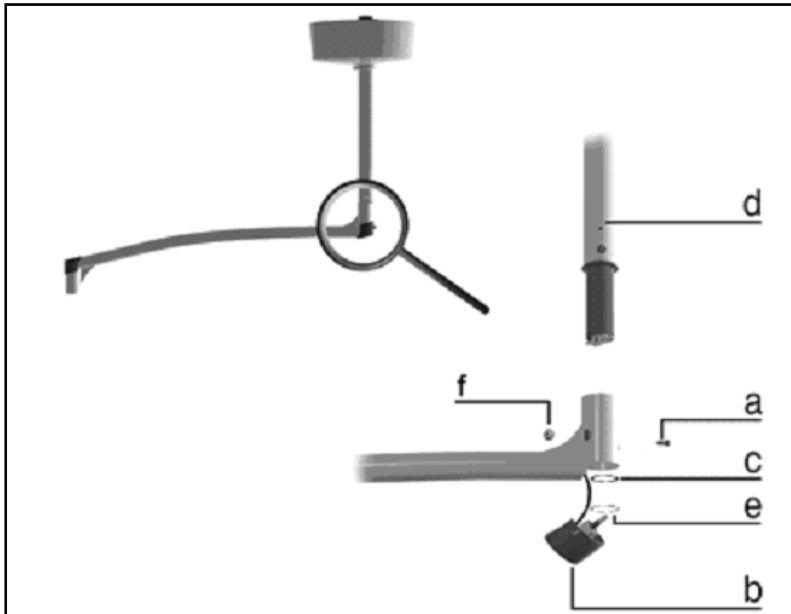

Installing the Extender Arm with Spring Arm

	WARNING Danger of injury	If the washer (c) is not installed, the retaining ring (e) can loosen. The equipment can then fall from its fixture and cause serious injuries. Always install the washer.
	WARNING - Electrical shock	The support system can become live if the power cables are damaged at the plug. The voltage can pose a danger to life. Install the plug carefully.



1. Unscrew the cross-slotted screw (a).
2. Remove the plug cap (b).
3. Lift the arm onto the shaft of the down tube (d).
4. Insert the washer (c) on the shaft and install the retaining ring (e).
5. Check whether the extender arm with spring arm is seated firmly.
6. Insert the safety screw (f) through the hole and thread into the extension shaft (d) using the included 2.5mm hex key.
7. Make sure the screw is fully seated against the extension shaft (d) of the down tube. The arm should rotate smoothly.
8. Insert the plug cap (b) into the shaft until it locks into position.
9. Refasten the cross-slotted screw (a) to secure the plug cap.

Mounting the Light Head

	<p>WARNING Danger of injury</p>	<p>The spring arm, if accidentally released when pressed down, can spring up and result in injuries. During the installation of the light head, no one should be present within range of the spring arm.</p>
	<p>CAUTION Danger of injury</p>	<p>Key must be properly installed to avoid safety hazard.</p>

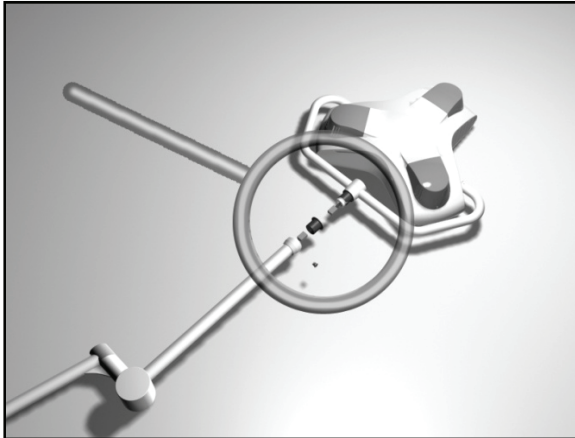

Figure 1

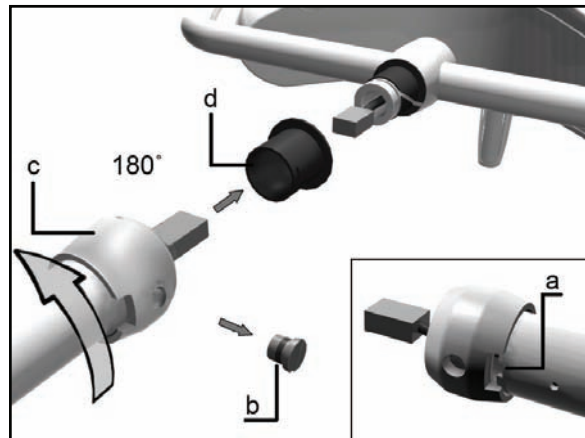

Figure 2

1. Figure 1 above shows the correct orientation of the spring arm to the light head.
2. Loosen the brake screw (b) and remove the protective cover (d) only.
3. Rotate the collar (c) 180° so that the slot in the collar aligns with the slot in the spring arm (a) illustrated in the lower right of figure 2.
4. Mate the electrical connectors.

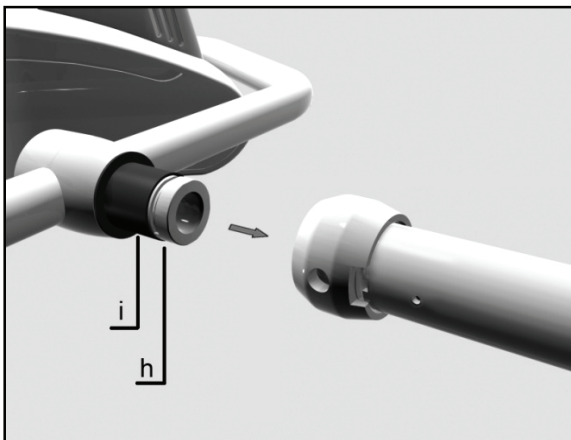

Figure 3

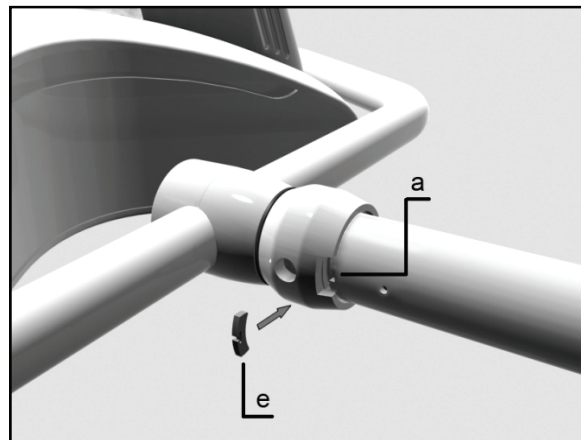



Figure 4

5.  Make sure the plastic bearing (i) is on the yoke and there is grease in the groove (h). (The connectors are not shown in figure 3.)
6. After the connectors are mated, push the yoke into the spring arm.

- Put the key (e) completely into the slot (a), so that the key is engaged into the yoke groove (h). See figure 4.

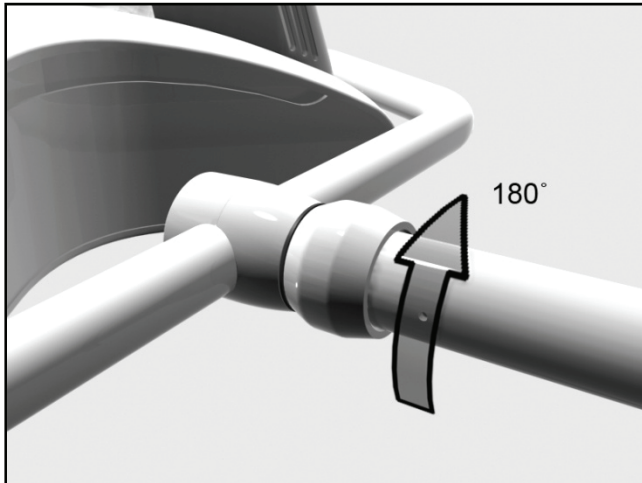



Figure 5

- Rotate the collar (c) 180 degrees as shown in figure 5.
-  Before installing the brake screw (b), check the attachment of the light head by pulling and rotating it at the same time. The light head should rotate smoothly and not pull out of the arm.

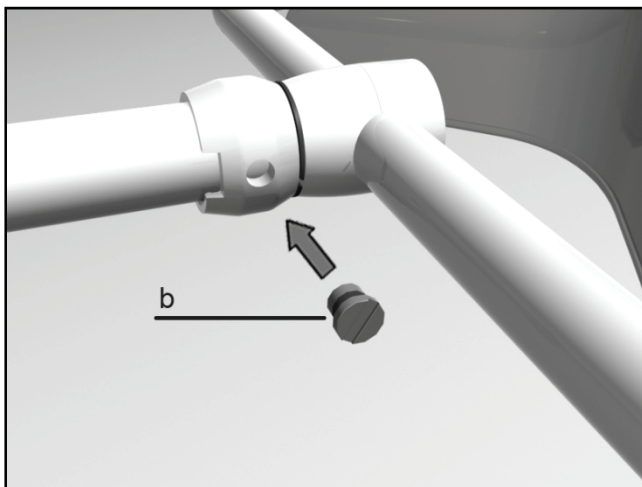

Figure 6

- Thread the brake screw (b) into the collar as shown in figure 6 and tighten it until the rotating joint has the desired friction.

Final Testing

Energize the light assembly by turning the wall switch on to check proper operation. The arm system should swing easily within the range of motion as illustrated on page 7.

Adjusting Arm Tension

The spring inside the arm is pre-adjusted from the factory. If, however, the light-head drifts up or down, please refer to the Operation & Maintenance manual for guidance on how to adjust this.

Static Inspection

 NOTE: The static (structural) inspection must be carried out before the installation of the wall or ceiling fastening.

- The strength of the construction must be designed, checked and certified by a structural engineer.
- The respective regional construction regulations that apply must be followed.
- If an erroneous hole is drilled by mistake (e.g. drilling of a reinforcement rod) the structural engineer who is responsible must be contacted, since adequate static load distribution in the ceiling may have been compromised.

Declaration of Acceptance:

It is hereby certified that the supporting wall/ceiling and the anchoring of the AIM-50™ suspension system is safe and adequately strong.

Project: _____

Anchoring (please check the one that is applicable):

- with counter-plate
- other

Location: _____

Signature/Stamp (Structural Engineer / Construction Authority)

Equipment Anchorage Diagrams

 EASE EQUIPMENT ANCHORAGE & SEISMIC ENGINEERING www.equipmentanchorage.com	DES. R. LA BRIE	SHEET 1
	JOB NO. 11-0786	OF 2 SHEETS
	DATE 1/1/08	
BURTON MEDICAL		
AIM-50/100 DOUBLE ARM LIGHT		

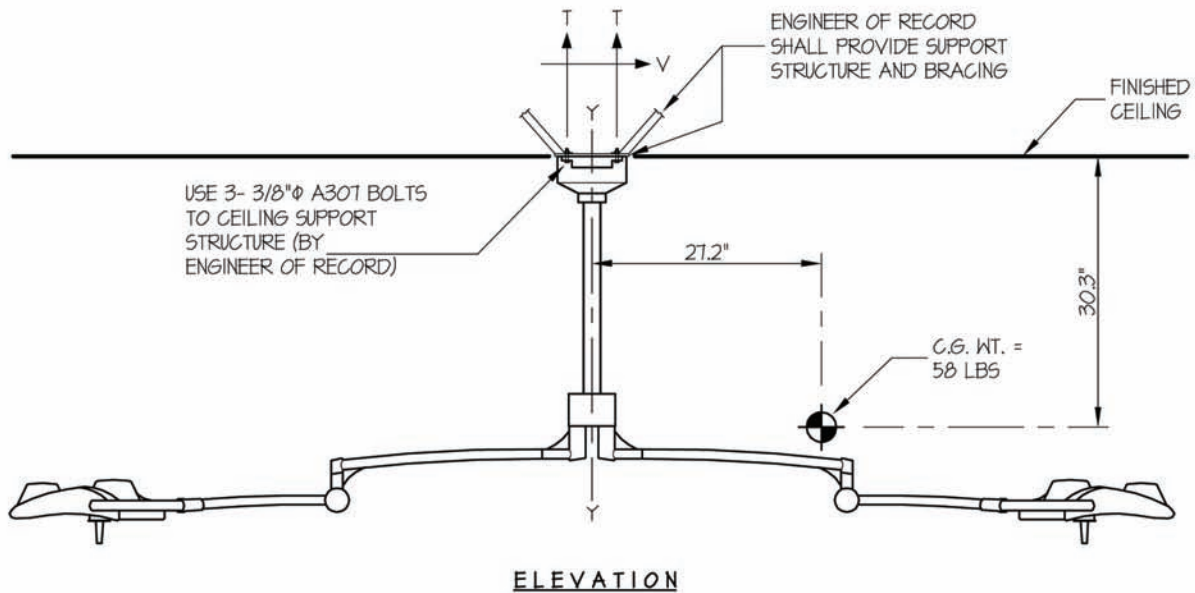

T_{MAX} = 836 LBS/BOLT
 V_{MAX} = 33 LBS/BOLT

NOTES:

- FORCES ARE DETERMINED PER 2007 CALIFORNIA BUILDING CODE SECTION 1613A AND ASCE 7-05 SECTIONS 12 AND 13. ALLOWABLE STRESS DESIGN IS USED.

HORIZONTAL FORCE (E_H) = 1.7 W_p (S_{DS} = 1.33, a_p = 2.5, I_p = 1.5, R_p = 2.5)

VERTICAL FORCE (E_V) = 0.19 W_p

- CENTER OF GRAVITY (C.G.) WEIGHT IS A MAXIMUM. THIS CALCULATION ENCOMPASSES ALL WEIGHTS UP TO THE MAXIMUM WEIGHT SHOWN.
- ARCHITECT OR STRUCTURAL ENGINEER OF RECORD SHALL PROVIDE SUPPORT STRUCTURE TO SUPPORT WEIGHTS AND FORCES SHOWN.



Single Ceiling Version - Plan Ceiling

 EASE EQUIPMENT ANCHORAGE & SEISMIC ENGINEERING www.equipmentanchorage.com	BURTON MEDICAL	DES. R. LA BRIE	SHEET 2 OF 2 SHEETS
	AIM-50/100 DOUBLE ARM LIGHT	JOB NO. 11-0786	
		DATE 1/1/08	

SEISMIC ANCHORAGE

CEILING SUSPENDED

USE 3- 3/8"φ A307 BOLTS
 TO CEILING SUPPORT
 STRUCTURE (BY
 ENGINEER OF RECORD)

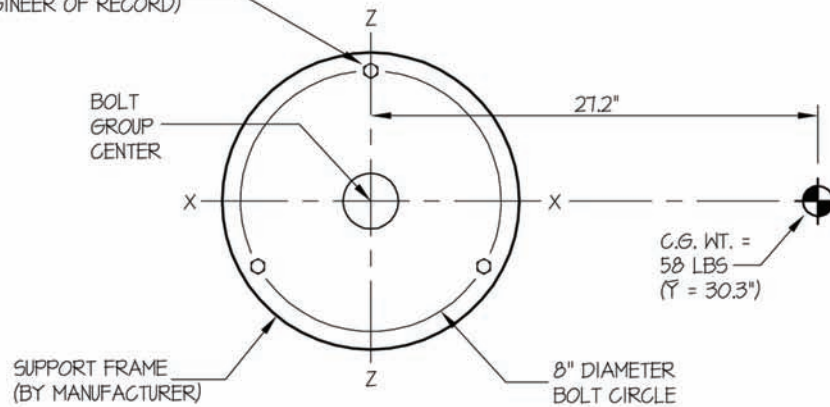

PLAN AT CEILING

LOADS:

WEIGHT = 58 LBS
 HORIZONTAL FORCE (E_h) = 1.7 W_p = 99 LBS
 VERTICAL FORCE (E_v) = 0.19 W_p = 11 LBS

BOLT GROUP PROPERTIES:

$I_{X-X} = 24 \text{ in.}^4$
 $I_{Z-Z} = 24 \text{ in.}^4$
 $I_{Y-Y} = 48 \text{ in.}^4$

MOMENTS:

$M_{XX} = 99\#(30.3") + (58\# + 11\#)27.2" = 4,877\#\text{in}$
 $M_{ZZ} = 99\#(30.3") + (58\# + 11\#)27.2" = 4,877\#\text{in}$
 $M_{YY} = 0\#\text{in}$ (UNIT IS FREE TO ROTATE 360 DEGREES AROUND Y-Y AXIS)

BOLT FORCES:

TENSION (T)

$$T = \frac{4877\#\text{in}(4")}{24} + \frac{58\# + 11\#}{3} = 836 \text{ LBS/BOLT (MAX)}$$

SHEAR (V)

$$V = \frac{99\#}{3} = 33 \text{ LBS/BOLT (MAX)}$$

Cutting the Down Tube

If shortening the down tube is required, the following procedure applies:

1. Cut the down tube **from the top** to the appropriate length (the top of the down tube has 2 holes, the bottom has 6 holes).
2. Drill new holes on the top of the down tube according to the drawing below.

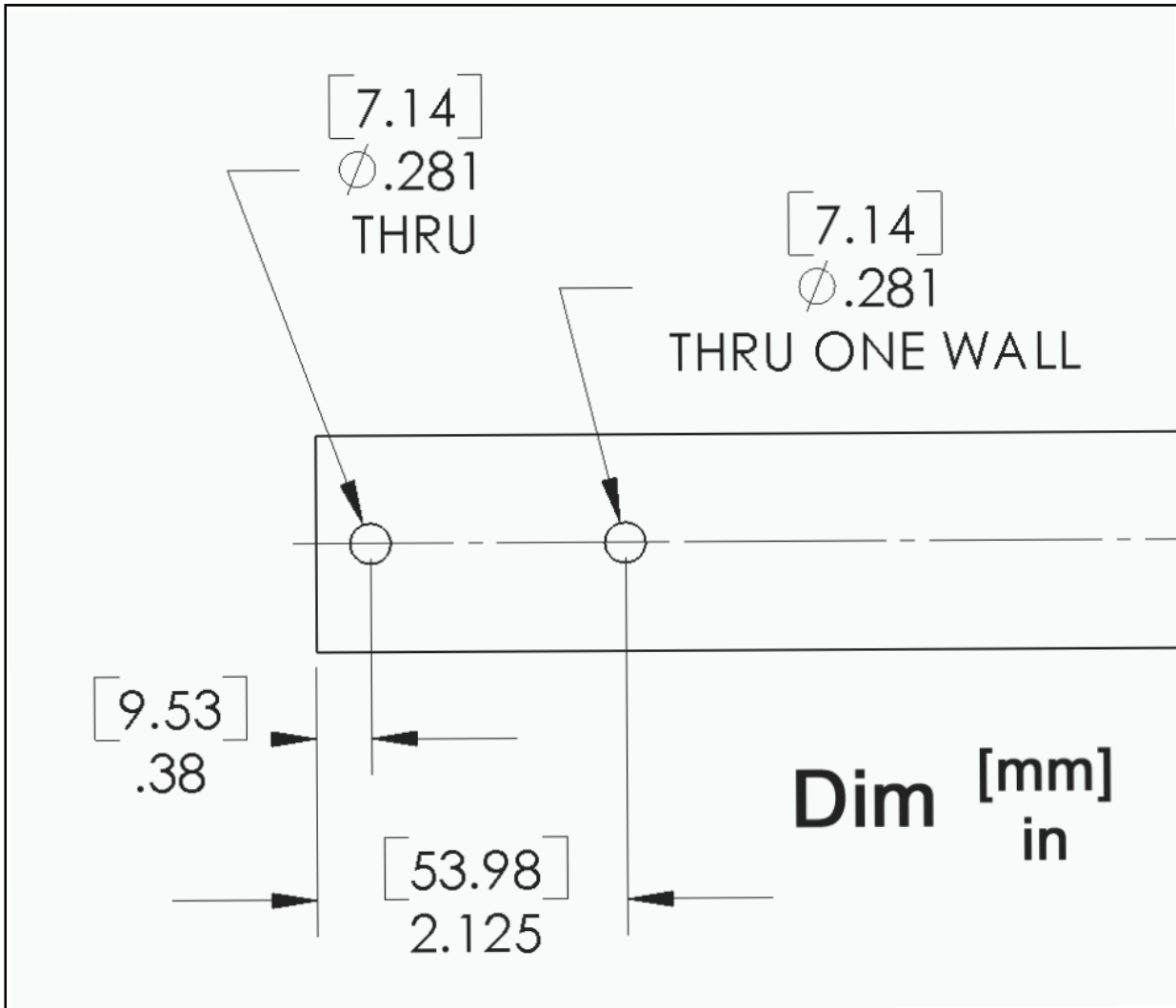



Luxo Medical Products

BURTON MEDICAL

21100 Lassen Street

Chatsworth, CA 91311 USA

Phone: 800-444-9909, 818-701-8700

Fax: 800-765-1770, 818-701-8725

www.burtonmedical.com



The Right Light

